

# INTERRUPTABLE FLUSH MECHANISM



The Interruptable flush Mechanism means you flush only the required amount of water.  
It fits most front lever operated cisterns.

- + Flush as much water as you need.
- + Interruptable valve can combine saving water and money, helping to reduce water bills.
- + Fits all front access cisterns.
- + Complete with chromed cistern lever and adjustable linkage to valve.



## MAIN CHARACTERISTICS

### • How does it work?

- Release handle to give part flush once pan is clear.
- Use in a cistern with front lever holes or to replace existing flush mechanism.
- Adjustable lift rod to fit most applications.
- Operates with a light touch to lever only.

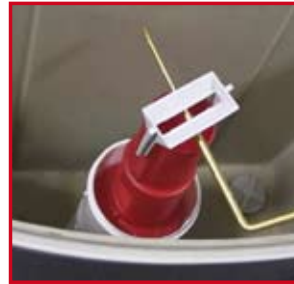

## TECHNICAL CHARACTERISTICS

### Interruptable flush mechanism

- 1 1/2" outlet
- Reversible for Left or Right hand applications
- Valve removable from base without dismantling cistern
- Variable valve height adjustment
- 10 years guarantee
- WRAS approved
- **Packaging:**  
The Wirquin Interruptable mechanism is available in a bag.

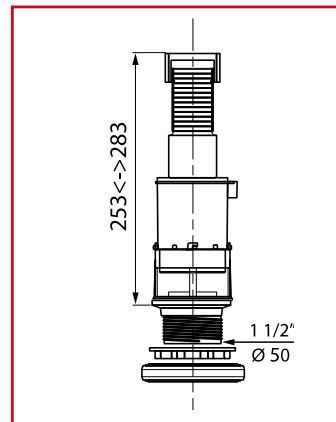

## PROGRAMME

Description	Product code	Code EAN	Pack	Box Qty
INTERRUPTABLE FLUSH MECANISM 1 1/2"	10000003	3375537160877	Bag	25